

**SERVICE REPAIR**

**MANUAL**

Hyster A476 (T5Z) Forklift Forklift

***HYSTER***

# PERIODIC MAINTENANCE

T5Z [A476];  
T7Z [A477];  
C60Z [A478];  
C80Z [A479]

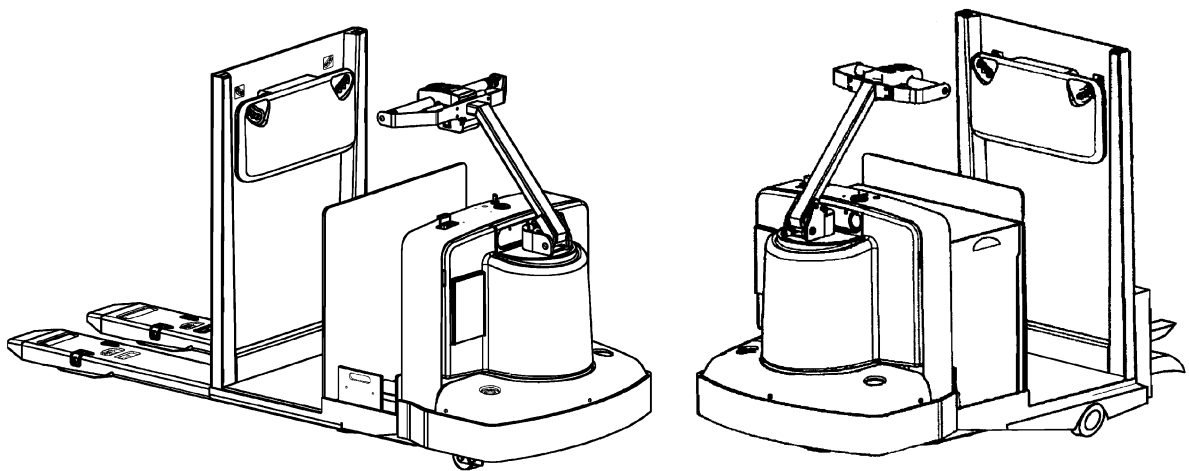

# ***HYSTER***

# SAFETY PRECAUTIONS

## MAINTENANCE AND REPAIR

- When lifting parts or assemblies, make sure all slings, chains, or cables are correctly fastened, and that the load being lifted is balanced. Make sure the crane, cables, and chains have the capacity to support the weight of the load.
- Do not lift heavy parts by hand, use a lifting mechanism.
- Wear safety glasses.
- **DISCONNECT THE BATTERY CONNECTOR** before doing any maintenance or repair on electric lift trucks. Disconnect the battery ground cable on internal combustion lift trucks.
- Always use correct blocks to prevent the unit from rolling or falling. See **HOW TO PUT THE LIFT TRUCK ON BLOCKS** in the **Operating Manual** or the **Periodic Maintenance** section.
- Keep the unit clean and the working area clean and orderly.
- Use the correct tools for the job.
- Keep the tools clean and in good condition.
- Always use **HYSTER APPROVED** parts when making repairs. Replacement parts must meet or exceed the specifications of the original equipment manufacturer.
- Make sure all nuts, bolts, snap rings, and other fastening devices are removed before using force to remove parts.
- Always fasten a **DO NOT OPERATE** tag to the controls of the unit when making repairs, or if the unit needs repairs.
- Be sure to follow the **WARNING** and **CAUTION** notes in the instructions.
- Gasoline, Liquid Petroleum Gas (LPG), Compressed Natural Gas (CNG), and Diesel fuel are flammable. Be sure to follow the necessary safety precautions when handling these fuels and when working on these fuel systems.
- Batteries generate flammable gas when they are being charged. Keep fire and sparks away from the area. Make sure the area is well ventilated.

**NOTE:** The following symbols and words indicate safety information in this manual:



### **WARNING**

**Indicates a condition that can cause immediate death or injury!**



### **CAUTION**

**Indicates a condition that can cause property damage!**

## TABLE OF CONTENTS

Introduction.....	1
General.....	1
Drive Unit Compartment Covers.....	1
Remove.....	1
Install.....	1
How to Move a Disabled Truck.....	2
How to Tow the Truck.....	3
How to Put the Truck on Blocks.....	4
How to Raise Drive/Steer Tire.....	4
How to Raise the Load Wheels.....	4
Special Precautions.....	5
Maintenance Schedule.....	6
Maintenance Procedures Every 8 Hours or Daily.....	9
Checks With the Key Switch OFF.....	9
Safety Labels.....	9
Battery.....	10
Frame.....	10
Load Wheels, Drive Tire, and Casters.....	10
Lift Linkage (C60Z and C80Z).....	11
Coupler (T5Z and T7Z).....	11
Steering Operation.....	11
Checks With the Key Switch ON.....	11
Control Handle.....	11
Gauges.....	11
Fuses.....	12
High Speed Switch.....	12
Hydraulic (C60Z and C80Z).....	12
Hand Brake.....	12
Maintenance Procedures Every 350 Hours or Every 2 Months.....	13
Battery Equalizing Charge.....	13
Coupler Lubrication (T5Z and T7Z).....	13
Control Handle Pivot.....	14
Brakes.....	14
Drive Tire and Wheel.....	14
Drive Unit Assembly.....	14
Check Oil Level.....	14
Motor Brushes.....	15
Maintenance Procedures Every 2000 Hours or Yearly.....	16
Load Wheel Bearings (T5Z and T7Z).....	16
Remove.....	16
Inspect.....	16
Install.....	16
Contactor.....	18
Inspecting the Contacts.....	18
Hydraulic System (C60Z and C80Z).....	18
Changing the Hydraulic Oil.....	18
Master Drive Unit.....	23
Drive Unit Gear Oil.....	23
Welding Repairs.....	24
Battery Maintenance.....	24
How to Charge Battery.....	24

**Thanks very much for your reading,  
Want to get more information,  
Please click here, Then get the complete  
manual**

**JustClickHere** 

**NOTE:**

**If there is no response to click on the link above,  
please download the PDF document first, and then  
click on it.**

**Have any questions please write to me:  
[admin@servicemanualperfect.com](mailto:admin@servicemanualperfect.com)**

### TABLE OF CONTENTS (Continued)

How to Change Battery .....	25
Adjusting the Battery Spacers.....	25
Changing Battery With Rollers .....	26
Remove .....	26
Install.....	27
Remove Battery Using Overhead Crane.....	27
Install Battery Using Overhead Crane.....	27
Battery Specifications .....	28

This section is for the following models:

T5Z [A476];  
T7Z [A477];  
C60Z [A478];  
C80Z [A479]

## Introduction

### GENERAL

This manual contains the instructions for periodic maintenance and inspection and a Maintenance Schedule.

The Maintenance Schedule has time intervals for inspection, lubrication, and periodic maintenance. The time intervals are based on normal operation. Normal operation is considered to be one 8-hour shift per day in a relatively clean environment on an improved surface. Multiple shifts, dirty operating conditions, etc., will require a reduction in the recommended time periods in the Maintenance Schedule.



### WARNING

**DO NOT make repairs or adjustments unless you have authorization and training. Repairs and adjustments that are not correct can create dangerous operating conditions.**

**DO NOT operate a truck that needs repairs. Report the need for repairs to your supervisor immediately. If repair is necessary, attach a DO NOT OPERATE tag to the control handle.**

Some users have service personnel and facilities to perform the procedures listed in the Maintenance Schedule. Service Manuals are available from your Hyster® lift truck dealer to help users who do their own repairs.

Your Hyster lift truck dealer has the trained personnel and equipment to conduct a complete program of inspection, lubrication, and maintenance. This complete program will help your truck operate better over a longer period of time.

**NOTE:** The front end of the truck is the control handle end. Forward travel is movement with the load wheels trailing. Reverse is travel with the drive tire

trailing. Left and right refer to the operator's left- and right-hand sides when standing on the truck, driving in the forward direction. See Figure 1.

### DRIVE UNIT COMPARTMENT COVERS

Many procedures require access to the drive unit compartment. The drive unit compartment is located at the front of the truck in front of the battery and below the control handle assembly. Two covers must be removed to access the drive unit compartment. The covers must be correctly reinstalled to protect the electrical system and other components housed in the drive unit compartment.

#### Remove

1. Remove the three screws retaining the lower drive unit compartment cover.
2. Lift the lower cover from the drive unit compartment.
3. Pull the bottom edge on one side of the upper cover from the drive unit compartment. Continue pulling around the edge of the cover until completely removed from the truck.

#### Install

1. Place the top corners of the upper cover into the retaining clips in the drive unit compartment.
2. Working around each side, bump the cover into place using the heel of the hand or a rubber hammer.
3. Place the lower cover into the bottom of the drive unit compartment.
4. Secure lower cover into place using three screws.

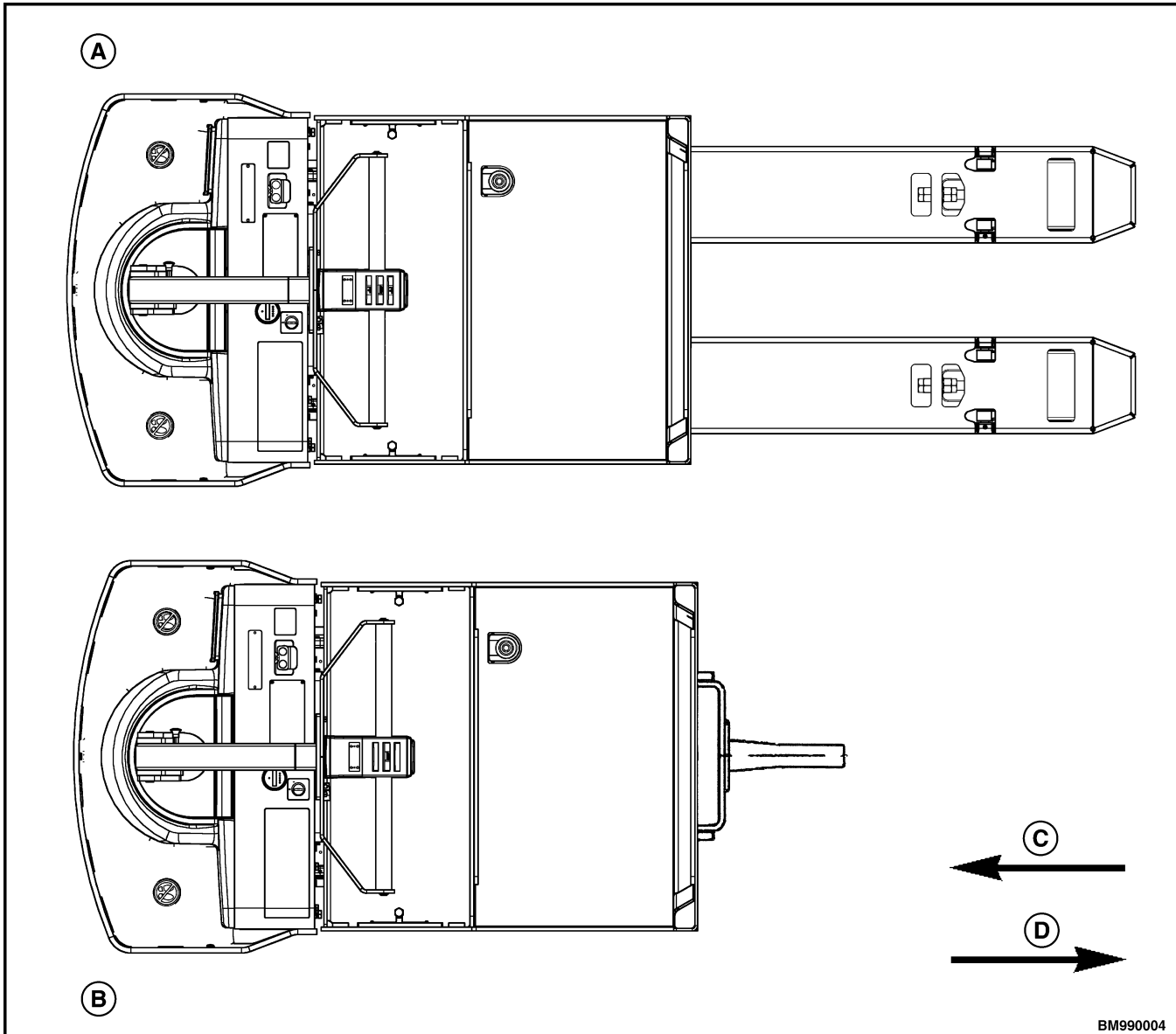

A. RH SIDE  
B. LH SIDE

C. FORWARD  
D. REVERSE

*Figure 1. Truck Orientation*

## HOW TO MOVE A DISABLED TRUCK

Trucks are not normally towed. If the traction system will not operate, make repairs at the location, if possible. If the truck must be towed, tow the truck forward (in the direction of the control handle).



### CAUTION

**Never attempt to tow by fastening any towing device to the control handle.**

Carefully attach the tow chain completely around the motor compartment and battery compartment. Make sure the tow chain is installed on the truck so the chain will not cause damage. Make sure the parking brake is released on the truck. Steer the truck with the control handle while it is being towed. **DO NOT** get between the towing vehicle and the disabled truck.



## How to Tow the Truck

### **WARNING**

Use extra care when moving a truck during the following conditions:

- Brake does not operate correctly
- Steering does not operate correctly
- Tire is damaged
- Traction conditions are bad

If there is no power, the drive wheel will not turn freely. Poor traction can cause the disabled truck or towing vehicle to slide. Grades will require additional distance to stop.

Never carry a disabled truck unless it **MUST** be moved and cannot be towed. The lift truck used to lift the disabled truck **MUST** have a rated capacity equal to or greater than the weight of the truck. See the nameplate on the truck for the approximate total weight. The fork spread must be equal to half the width of the disabled truck. The forks must extend the full width of the disabled truck. Put the weight of the disabled truck at the center of the forks and be careful not to damage the underside of it. Tilt the mast back and travel slowly.

Be sure to stay clear of the tow chain, towing vehicle, and truck during the towing operation to prevent injury.

### **CAUTION**

Never tow the lift truck faster than the speed of a person walking. Steering can be difficult and motor damage can occur at higher speeds. Always tow smoothly without sudden starts. Never tow the lift truck using the control handle. Make sure the brake has been released during towing.

1. Remove the drive unit compartment covers. See Drive Unit Compartment Covers. Fasten the tow chain completely around the motor and battery

compartments. Make sure the tow chain has the capacity to tow the weight. The chain must not cause damage to either truck.

2. Connect the battery. Turn the key switch to the **ON** position and the parking brake switch to the **OFF** position.

### **WARNING**

Make sure no one except the driver is near the truck during towing. Both the tow truck and the disabled truck can cause an injury during towing.

### **CAUTION**

Travel slowly and **DO NOT** tow on grades. **NEVER** tow the lift truck faster than a normal walking speed. Always tow smoothly without sudden starts or stops.

Until repairs are complete, keep a **DO NOT OPERATE** tag on the control handle.

3. Tow the lift truck slowly while a driver steers the truck while walking along side.
4. If towing with lift truck, add weight to the forks of the lift truck if the drive wheels are near the forks. The total weight of the lift truck and load must be equal to or greater than the weight of the disabled truck. Install a load of approximately half the maximum capacity on the forks of the towing lift truck. This load will increase the traction of the lift truck.

**DO NOT** add weight to the forks if the lift truck used for towing has a master drive unit (MDU) or drive unit on the opposite end as the forks. Additional weight on the forks may **DECREASE** the traction of the drive wheel. Make sure that the towing truck has a total weight equal to or greater than the weight of the disabled truck. Keep the load on the forks lowered as much as possible.

## HOW TO PUT THE TRUCK ON BLOCKS

### WARNING

**DO NOT put the truck on blocks if the surface is not solid, even, and level. Make sure that any blocks used to support the truck are solid, one-piece units. Put a block in front and back of the tires touching the ground to prevent movement of the lift truck.**

**DO NOT raise the truck by attaching an overhead lifting device to areas that can be damaged. Some points of the truck are not designed to support the weight of the truck. The truck can be damaged or it can fall, causing serious injury. Attach the chain or sling to a support structure of the lift truck frame.**

**DO NOT** make repairs or adjustments unless specifically authorized to do so. Repairs and adjustments must be performed by trained service technicians.

### How to Raise Drive/Steer Tire

1. Put blocks on both the front and back sides of the load wheels to prevent movement of the truck.

Use a special low-clearance hydraulic jack, crane, or a lift truck to raise the drive tire. Make sure that the jack, crane, or lift truck has the correct capacity rating. The capacity must equal at least 2/3 the weight of the truck, including the battery. See the nameplate for truck weight. On

the C60Z and C80Z, the lifting mechanism may be used to lift the truck and lower it onto blocks.

2. Raise the lift truck enough to suspend the drive tire. Install hardwood blocks under the frame on both sides of the truck.

### How to Raise the Load Wheels

### WARNING

**Never raise the truck any higher than necessary to change the load wheels. Always raise both sides at the same time. Raising either side too high can cause the truck to tip over and cause damage or serious injury.**

1. Put blocks on both the front and back sides of the drive tire to prevent movement of the truck.
2. Use an overhead lifting device and web sling under the truck at the rear to raise the load wheels. A lift truck can also be used to raise the rear of the truck. Make sure the overhead lifting device and web sling or lift truck has a capacity of at least 2/3 the total weight of the truck being lifted, including the battery. See the nameplate for the lift truck weight. On the C60Z and C80Z, the lifting mechanism may be used to lift the truck and lower onto blocks.
3. Raise the truck enough to suspend the load wheels. Install blocks under the truck to the front of the load wheels to support the truck.

## Special Precautions



### WARNING

**DO NOT** make repairs or adjustments unless you have both authorization and training. Repairs and adjustments that are not correct can create a dangerous operating condition. **DO NOT** operate a lift truck that needs repairs. Report the need for repairs to your supervisor immediately. If repair is necessary, put a **DO NOT OPERATE** tag on the control handle. Remove the key from the key switch.

Disconnect the battery and separate the connector before opening the drive unit compartment cover or inspecting or repairing the electrical system. If a tool causes a short circuit, the high current flow from the battery can cause personal injury or property damage.

Some checks and adjustments are done with the battery connected. **DO NOT** connect the battery until the procedure tells you to do so. Never have any metal on your fingers, arms, or neck. Metal items can accidentally make an electrical connection and cause injury.

Before performing any tests or adjustments, block the lift truck to prevent unexpected movement.

The capacitor in the transistor controller can hold an electrical charge after the battery is disconnected. To prevent an electrical shock and personal injury, discharge the capacitor before inspecting or repairing any component in the drive unit compartment. Wear safety glasses. Make certain that the battery has been disconnected.



### CAUTION

To avoid controller damage, always disconnect the battery, discharge the capacitor, and never put power to the controller while any power wires are disconnected. Never short any controller terminal or motor terminal to the battery. Make sure to use proper procedure when servicing the controller.

1. Block load wheels to prevent lift truck from moving.
2. Turn the key switch to the **OFF** position and disconnect the battery.
3. Discharge the capacitors in the controllers by connecting a 200-ohm, 2-watt resistor across the controller's B+ and B- terminals. **DO NOT** short across the motor controller terminals with a screwdriver or jumper wire.
4. Remove the 200-ohm, 2-watt resistor before reconnecting the battery. See Figure 2.

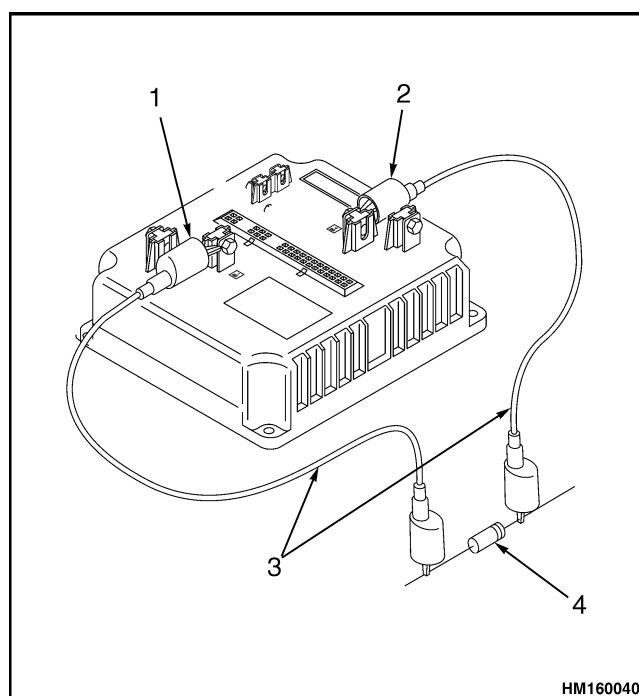

1. POSITIVE CONNECTION
2. NEGATIVE CONNECTION
3. INSULATED JUMPER WIRES
4. 200-OHM, 2-WATT RESISTOR

*Figure 2. Discharging the Capacitors*

## Maintenance Schedule

The maintenance schedule has time intervals for inspection, lubrication, and maintenance for your lift truck. The service intervals are given both in operating hours recorded by the BDI/hourmeter and in calendar time. The recommendation is to use the interval that comes first.

**CAUTION**

Trucks operating in nonstandard or severe conditions may require special optional environmental packages, additional maintenance

**procedures, more frequent service intervals, and/or special lubricants.**

The maintenance schedules are made according to the maximum service intervals for average conditions. Inspect and lubricate more frequently when operating in dirty or difficult conditions.

The approximate locations of the items indicated in Table 1 are shown in Figure 3.

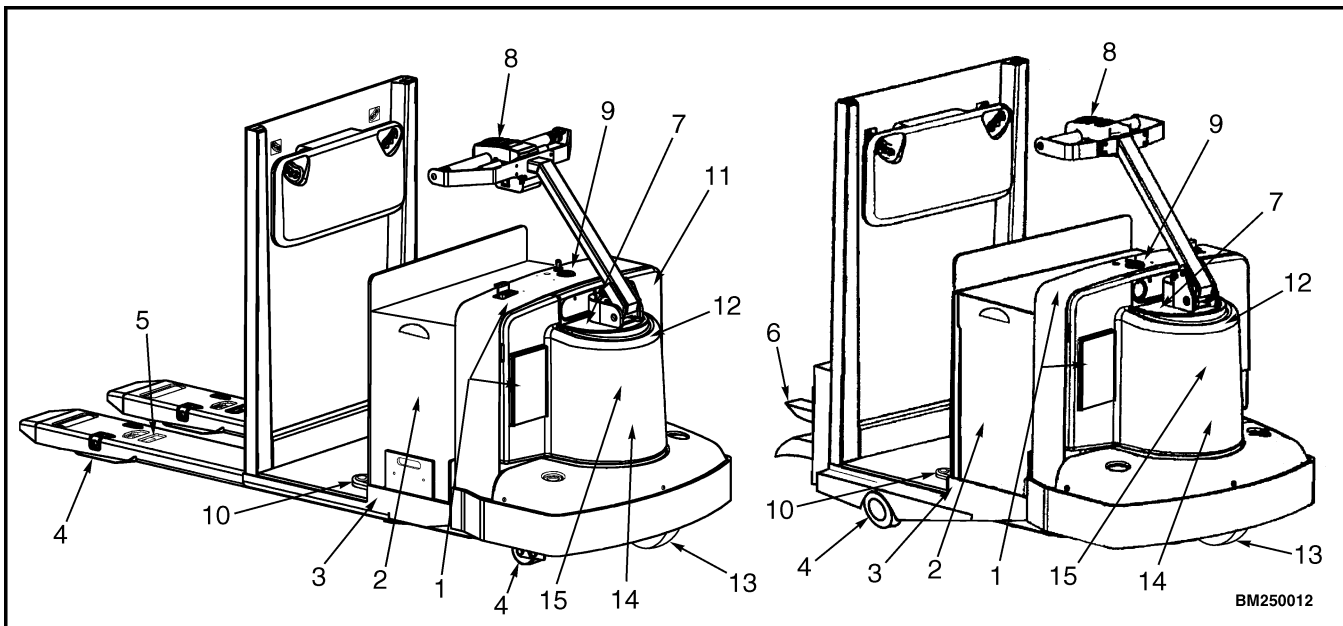

Figure 3. Maintenance Points

Table 1. Maintenance Schedule

Item No.	Item	8 hr or 1 day <sup>3</sup>	350 hr or 2 month <sup>3</sup>	2000 hr or 1 year <sup>3</sup>	Procedure or Quantity	Specification
1	Safety Labels and Operating Manual	X			Replace if Necessary	See <b>Parts Manual</b>
2	Battery	X			Check Water Level	
			X			Equalization Charge <sup>1</sup>
3	Frame	X			Check Condition	
X=Check C=Change L=Lubricate						
<b>NOTE:</b> Never use steam to clean electrical parts.						

Table 1. Maintenance Schedule (Continued)

Item No.	Item	8 hr or 1 day <sup>3</sup>	350 hr or 2 month <sup>3</sup>	2000 hr or 1 year <sup>3</sup>	Procedure or Quantity	Specification
4	Load Wheels (T5Z and T7Z)	X			Check Condition	
				L	Repack Bearings Replace if Necessary	Multipurpose Grease <sup>2</sup>
	Load Wheels and Casters (C60 and 80Z)	X			Check Condition	
			L		Lubricate Fittings	Multipurpose Grease <sup>2</sup>
5	Lift Linkage (C60Z and C80Z)	X			Check Operation	
			L		Lubricate	Multipurpose Grease <sup>2</sup>
6	Coupler (T5Z and T7Z)	X			Check Operation	
			L		Lubricate	SAE 20W or 30W Engine Oil
7	Steering Bearing	X			Check Operation	
				L	Lubricate	Synthetic Grease <sup>6</sup>
8	Control Handle					
	Directional/Speed Control	X			Check Operation	
	Lift Lower Controls (C60Z and C80Z)	X				
	Horn	X				
	Pivot Pin and Spring-Loaded Adjustment Pin	X	L		Lubricate	SAE 20W or 30W Engine Oil
9	Electrical					
	Gauges	X			Check Operation	
	Fuses	X			Check Condition	
	Contactors			X	Check Condition	
10	High Speed Switch	X			Check Operation	
X=Check C=Change L=Lubricate						
<b>NOTE:</b> Never use steam to clean electrical parts.						

Table 1. Maintenance Schedule (Continued)

Item No.	Item	8 hr or 1 day <sup>3</sup>	350 hr or 2 month <sup>3</sup>	2000 hr or 1 year <sup>3</sup>	Procedure or Quantity	Specification
11	Hydraulic System	X			Check Level	
				C	1.1 liter (1.2 qt)	Hydraulic Oil <sup>6</sup>
	Hydraulic Hoses and Fittings	X			Inspect for Leaks, Visible Damage, and Defects	Repair or Replace as Necessary
			X		Inspect for Kinked, Flattened, Stiff, or Charred Hoses	Replace as Necessary
12	Brakes	X			Check Operation	Releases and Applies Smoothly
	C60Z and C80Z		X		Check Operation	Hold On 10% Grade <sup>4</sup>
	T5Z and T7Z		X		Check Operation	Hold On 5% Grade <sup>5</sup>
13	Drive Tire and Wheel	X			Check Condition	
	Lug Bolt Torque (T5Z and C60Z)		X		Tighten if Required	195 N•m (144 lbf ft)
	Lug Nut Torque (T7Z and C80Z)		X		Tighten if Required	201 N•m (148 lbf ft)
14	Drive Unit Gear Oil					
	(C60Z and T5Z)		X	C	1.7 liter (1.8 qt)	SAE 80W-90 Gear Oil
	(C80Z and T7Z)		X	C	2.0 liter (2.1 qt)	SAE 80W-90 Gear Oil
X=Check C=Change L=Lubricate						
<b>NOTE:</b> Never use steam to clean electrical parts.						

Table 1. Maintenance Schedule (Continued)

Item No.	Item	8 hr or 1 day <sup>3</sup>	350 hr or 2 month <sup>3</sup>	2000 hr or 1 year <sup>3</sup>	Procedure or Quantity	Specification
15	Motor-Traction					
	Brushes (C60Z and T5Z)		X		Measure	15.00 mm (.59 in.) Min. Brush Length
	Brushes (C80Z and T7Z)		X		Measure	15.00 mm (.59 in.) Min. Brush Length
	Springs		X		Check Condition	
	Contactors Tips			X	Disassemble	Check Condition
<sup>1</sup> Equalization charge approximately each month but not more than each week. <sup>2</sup> Use Amsoil® GHD multipurpose grease (lithium complex) with 2 to 4% molybdenum disulfide. <sup>3</sup> Whichever comes first. <sup>4</sup> With capacity load. <sup>5</sup> With 2268 kg (5000 lb) load (trailer plus load weight). <sup>6</sup> Use ISO VG 46 antiwear (HCE-140) for standard configurations. Use Exxon Univis® HVI 26 (synthetic) for freezer, cold storage, arctic, and food processing configurations.						
X=Check C=Change L=Lubricate						
<b>NOTE:</b> Never use steam to clean electrical parts.						

## Maintenance Procedures Every 8 Hours or Daily

### CHECKS WITH THE KEY SWITCH OFF

**NOTE:** Be certain to read and understand the information covered in the Introduction section before performing any of the **Maintenance Procedures** that follow.



#### **WARNING**

The capacitor in the transistor controller can hold an electrical charge after the battery is disconnected. To prevent electrical shock and injury, discharge the capacitor before inspecting or repairing any component in the drive unit compartment. Wear safety glasses. Make certain the battery has been disconnected.

Put the lift truck on a level surface. Lower the forks and turn the key switch to the **OFF** position. Disconnect the battery. Open the MDU compartment cover. Discharge the capacitor. Check for leaks and conditions that are not normal. Clean any oil or other

spills. Make sure that lint, dust, paper, and other materials are removed from the compartments.

### Safety Labels



#### **WARNING**

If labels that have warnings or instructions are damaged, they must be replaced immediately.

Check that all safety labels are installed in the correct locations on the lift truck. Make sure that all labels are not damaged and that they can be read. If necessary, see the **Parts Manual** for your lift truck for the correct location of the labels.

Safety labels are installed on the lift truck to give information about possible hazards. It is important that all safety labels are installed on the lift truck and can be read. See the **Parts Manual** for label placement for your lift truck.

## Battery

### WARNING

**DO NOT lay tools on top of the battery.**

**The acid in the electrolyte can cause injury. If the electrolyte is spilled, use water to flush the area. Make the acid neutral with a solution of sodium bicarbonate (soda) and water. Acid in the eyes must be immediately flushed with water continuously for 15 minutes, then seek medical attention.**

**Batteries generate explosive fumes. Keep the vents in the caps clean. Keep sparks or open flames away from the battery area. DO NOT make a spark from the battery connections. Disconnect the battery when performing maintenance.**

**The battery must fit the battery compartment so the battery restraint panels will operate correctly. Use spacers to prevent the battery from moving more than 13.0 mm (0.5 in.) in any direction.**

**NOTE:** Battery water levels can be maintained without removing the battery from the truck.

Check for loose or broken electrical connections and damaged wires or cables. Examine the battery case for damage and leakage. See the battery dealer in the area to repair any damage to the battery or cables.

Check that the vent caps are clear. Check the level of the electrolyte daily on a minimum of one cell. Add only distilled water, as necessary, if the cell is low. If one cell is low, check the rest of the cells. The correct level is halfway between the top of the plates and the bottom of the fill hole. Use a hydrometer to check that the battery is not discharged below the minimum specific gravity given by the manufacturer and has enough charge to complete a work period. See How to Charge Battery in this section.

Remove the battery as described in the section **Industrial Battery** 2240 SRM 1. Check the battery case, connector, and cables for damage, cracks, or breaks. See the battery dealer in your area to repair any damage. Keep the battery case and the battery compartment clean and painted. Leaks and corrosion from the battery can cause a malfunction in the electric controls of the lift truck. Use a water

and soda solution to clean the battery and the battery compartment. Keep the top of the battery clean, dry, and free of corrosion.

Make sure the battery is the correct weight and size. Prevent side-to-side movement of the battery by adjusting the brackets on either side of the battery. The correct battery is specified in How to Change Battery and in the **Operating Manual**. The **Operating Manual** is located in the container on the Drive Unit cover. This is a permanent reference and must be available for use at all times.

## Frame

### WARNING

**Forklift truck frames and components may have polyurethane paint. Welding, burning, or other heat sufficient to cause thermal decomposition of the paint may release isocyanates. These chemicals are allergic sensitizers to the skin and respiratory tract and overexposure may occur without odor warning. Always utilize good industrial hygiene practices, including removal of all paint (prime and finish coats) to the metal around the area to be welded. Use local ventilation and/or supplied-air respiratory protection when repairing the frame.**

Check the frame for damage. Inspect for rust and cracks especially near welds. All surfaces of the frame should be covered with paint to prevent rust and corrosion. Heat can weaken metal, preventing some areas of the frame from being repaired. See Welding Repairs.

## Load Wheels, Drive Tire, and Casters

### CAUTION

**If the drive tire has been removed and installed, check all wheel bolts after 2 to 5 hours of operation. Tighten the bolts in a cross pattern (see Drive Tire and Wheel) to the correct torque value shown in the Maintenance Schedule. When the bolts stay tight after eight hours, the interval for checking the torque can be extended to 350 hours.**

Inspect the standard or optional casters, drive tire, and load wheels for damage. Inspect the tread and remove any objects that will cause damage. See Figure 4. Inspect the wheels and casters for loose or



missing parts. Remove any wire, strapping, or other material wound around the axles or casters.

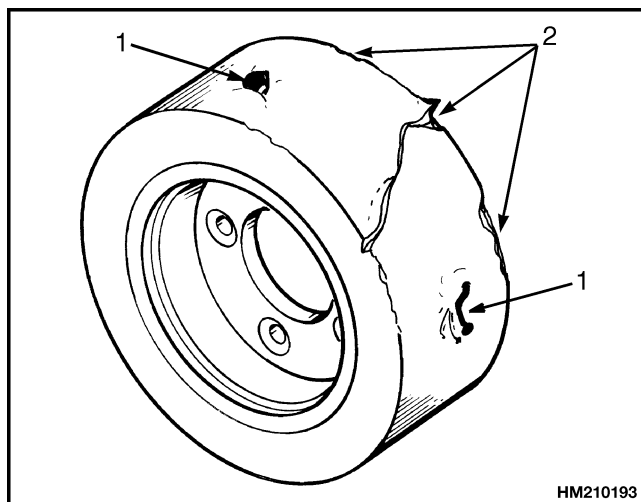

1. OBJECTS EMBEDDED IN TIRE.
2. GROOVES, CUTS, OR OTHER DAMAGE TO TIRE.

*Figure 4. Tire and Wheel Inspection*

### Lift Linkage (C60Z and C80Z)

A series of levers and rods compose the lift linkage. These devices are connected together and to the frame and lift cylinder in series. The lift cylinder applies force in only one direction. The lift linkage transfers that force to the load wheel linkage and the drive end frame linkage, lifting the truck and load evenly and smoothly. Many pivot points indirectly shoulder the weight of the truck and load. These points must be lubricated every 350 hours/2 months to ensure minimal resistance from friction and damage from heat.

### Coupler (T5Z and T7Z)

The coupler is mounted to the rear of the truck and can be released from the truck using a hand lever. The design of the coupler allows hand-free connections by backing the truck up to the connecting load until the coupler latches. Check that the hand lever moves easily with little resistance and returns to the latched position when released. A simple drop pin-type connector option is also available.

### Steering Operation

Check that the steering operates smoothly and gives good steering control. Move the handle to the left or right to steer the lift truck in the desired direction of

travel. Reposition the steering control handle up and down to ensure easy adjustment during use.

## CHECKS WITH THE KEY SWITCH ON

### Control Handle

#### **WARNING**

**Make sure the area around the lift truck is clear before moving the lift truck or checking for correct operation. Be careful when making the checks.**

Check that the speed/direction control and the foot switch for high speed operates as described in the **Operating Manual**. Also check that the horn switch is operational.

The speed/direction control is for selecting forward or reverse movement and the travel speed of the lift truck. The control is spring loaded and should return to the neutral position when the control is released. The control can be operated by either hand. The operator controls the speed and direction of travel by rotating the control in the desired direction. Maximum rotation of the control causes maximum travel speed. To stop or change direction, the operator rotates the control in the opposite direction. The lift truck will come to a stop. If the speed/direction control is not released when the lift truck stops, it will accelerate in the opposite direction. Changing the direction with the speed/direction control is called plugging. Arrows on the control indicate the direction of travel.

Check the operation of the horn. The key switch must be in the **ON** position for the horn to operate.

### Gauges

**NOTE:** The electrical controls will not operate until the key switch is turned to the **ON** position.

Check that all the instruments and controls operate as described in the **Operating Manual**. The **Operating Manual** is located in the container on the MDU cover. This is a permanent reference and must be available for use at all times.

Check the operation of the gauges. The key switch must be in the **ON** position for the gauges to operate. The battery discharge indicator/hourmeter displays the total operation hours. Periodic maintenance recommendations are based on these operating hours.

## Fuses

### **WARNING**

The capacitor in the transistor controller can hold an electrical charge after the battery is disconnected. To prevent electrical shock and injury, discharge the capacitor before inspecting or repairing any component in the drive unit compartment. Refer to Special Precautions. Wear the proper protective eyewear. Make certain the battery has been disconnected.

There is a control fuse located in a spring clip and a power fuse located on standoffs on the contactor panel. The contactor panel is located in the MDU compartment. Remove the MDU compartment cover to check the fuses. Check that the fuses are the correct ampere size and are not burned. Some types of fuses must be checked with an ohmmeter. Replace a bad fuse with a fuse with the correct rating. **NEVER** use a fuse with a higher rating. The power and the control fuses have the following ratings:

Control Fuse	Traction Power Fuse
5 Amps	400 Amps

## High Speed Switch

The high speed switch is a foot switch located in the floor of the driver's compartment. The high speed function activates when:

- The key switch is in the **ON** position.
- The parking brake switch is in the **OFF** position.
- The directional controls of the control handle are rotated.
- The battery discharge indicator/hourmeter (BDI) reads 20% or greater.
- The high speed switch is depressed.

Test for proper operation of the high speed switch daily to ensure the truck is performing at optimal efficiency.

## Hydraulic (C60Z and C80Z)

### **WARNING**

**Always wear the proper protective equipment including eye protection and petroleum-resistant gloves when handling hydraulic oil. Thoroughly wash oil from exposed areas of skin as soon as possible.**

**Completely lower forks to relieve hydraulic pressure before disassembling any part of the lift pump or disconnecting any hydraulic hoses.**

**The hydraulic oil is hot at normal operating temperatures. Be careful when draining the oil.**

**Never check for leaks by putting hands on hydraulic lines or components under pressure. Hydraulic oil under pressure can be injected into the skin.**

### **CAUTION**

**Protect the hydraulic system from dirt and contaminants when servicing the hydraulic system.**

**Never operate the pump without the proper amount of oil in the hydraulic system. The operation of the hydraulic pump with low oil levels will damage the pump.**

Inspect the hydraulic system for leaks and damaged or loose components.

Inspect all hydraulic hoses and fittings for leaks. Check for broken or defective clamping devices. Repair or replace any damaged components as necessary.

The hydraulic oil level must be checked daily. Operating a truck without enough hydraulic oil can cause substandard performance and can damage the hydraulic system. Fill the reservoir to the **MIN** mark with hydraulic oil.

## Hand Brake

### **WARNING**

**DO NOT operate a truck with an improperly functioning brake.**

A two-stage hand brake is mounted just below the control handle and connects to the control handle wiring harness. The hand brake assembly consists of two independent handles, various linkages, and three switches to perform two different braking functions. Check for proper operation of the brake. When either hand brake handle is placed in the first position, the controller places the traction motor into re-gen mode. This slows the truck by using opposing magnetic fields inside the traction motor. A spring-applied/electrically released brake is mounted to the

top of the traction motor. When the key switch is in the **ON** position and the parking brake is in the **OFF** position, the coil pulls the pressure plate away from the friction disc disengaging the brake. The brake is

applied when the brake handle is placed in the second position, the parking brake switch is in the **ON** position, or when the key switch is in the **OFF** position.

## Maintenance Procedures Every 350 Hours or Every 2 Months

### BATTERY EQUALIZING CHARGE

#### **WARNING**

**DO NOT** lay tools on the top of the battery.

The acid in the electrolyte can cause injury. If the electrolyte is spilled, use water to flush the area. Make the acid neutral with a solution of sodium bicarbonate (soda) and water. Acid in the eyes must be immediately flushed with water continuously for 15 minutes, then seek medical attention.

Batteries generate explosive fumes. Keep the vents in the caps clean. Keep sparks or open flames away from the battery area. **DO NOT** make a spark from the battery connections. Disconnect the battery when performing maintenance.

The battery must fit the battery compartment so the battery restraint panels will operate correctly. Use spacers to prevent the battery from moving more than 13.0 mm (0.5 in.) in any direction.

If the lift truck has been operated using a low battery, check the contactors for welded contacts **BEFORE** connecting a charged battery. The lift truck cannot be controlled if the contacts are welded.

#### **CAUTION**

Never connect the battery charger plug to the plug of the lift truck. You can damage the traction control circuit. Always make sure the charger voltage is the correct voltage for the battery.

An equalizing charge is an additional charge at a slow rate to balance the charge of the batteries. This is normally recommended once a month and no more than once a week.

### COUPLER LUBRICATION (T5Z AND T7Z)

The coupler linkage requires lubrication regularly. Lubricate the pivot point where all the parts intersect using an oil can and SAE 20W or 30W engine oil. Work the release handle back and forth to ensure total coverage and smooth operation. See Figure 5.

**NOTE:** Clean up any oil that drips onto the floor immediately.

Lubrication may be necessary at more frequent intervals, depending on operating conditions.

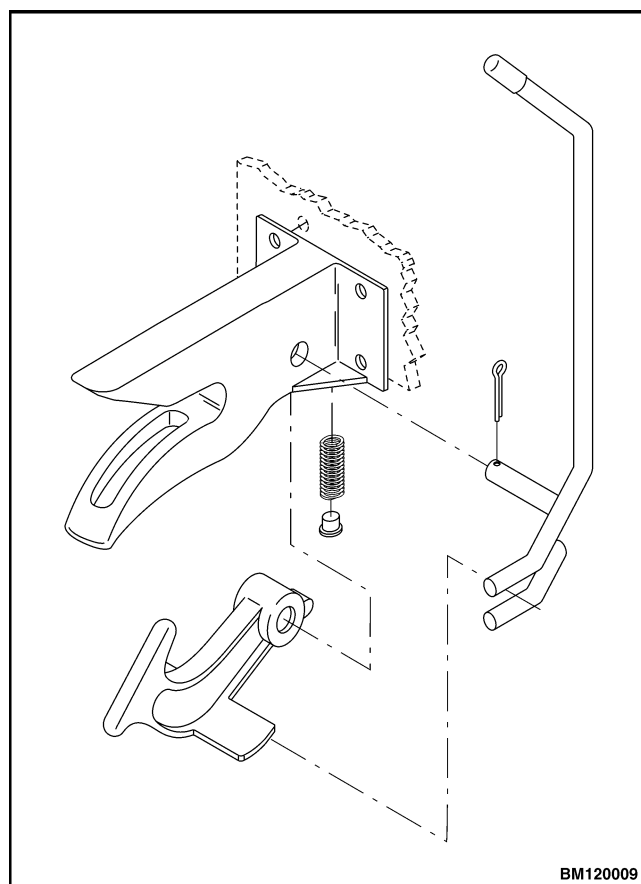

*Figure 5. Coupler Linkage Lubrication*

## CONTROL HANDLE PIVOT

The control handle is connected to the hub by a pivot pin. Bushings in the hub cushion the pin and help reduce wear. The handle only moves on the pivot when adjusting the control handle height. An adjusting pin locks the handle in place. Lubricate the pivot pin and the adjusting pin using motor oil.

## BRAKES

In addition to the 8-hour check for operation, test the brakes to ensure it will hold on grade to specification.

1. Load the truck to specification.  
2268 kg (5000 lb) (trailer plus load weight) - T5Z and T7Z  
Capacity Load - C60Z and C80Z
2. Slowly drive the truck up grade.  
5% Grade - T5Z and T7Z  
10% Grade - C60Z and C80Z
3. Hold the hand brake in the second position to stop the truck.

If the brake cannot hold the loaded truck on the specified grade, the brake must be repaired or replaced. Refer to the section **Brakes** 1800 SRM 963.

## DRIVE TIRE AND WHEEL

Inspect the wheel rim for rust and cracks. **DO NOT** weld a cracked wheel rim or straighten a bent rim. Welding, heating, or bending a wheel rim can weaken its capacity. Always replace damaged tires or wheel rims immediately. **DO NOT** operate a truck with a broken stud (or missing lug nuts or bolts). Make sure the drive wheel fasteners are tightened to the correct torque value. Tighten the fasteners in a criss-cross pattern. See Figure 6. Tighten to the correct torque value shown in Maintenance Schedule.

## DRIVE UNIT ASSEMBLY

### Check Oil Level

**NOTE:** The fill plug may be obstructed by the MDU. Push the control handle completely to the left or right to access the fill plug.

Check the level of lubricant by removing the fill plug and roll the truck slowly until the hole in the gear

lines up with the fill hole. There is enough lubricant when the lubricant is up to the bottom of the gear or halfway to the top of the gear. See Figure 7.

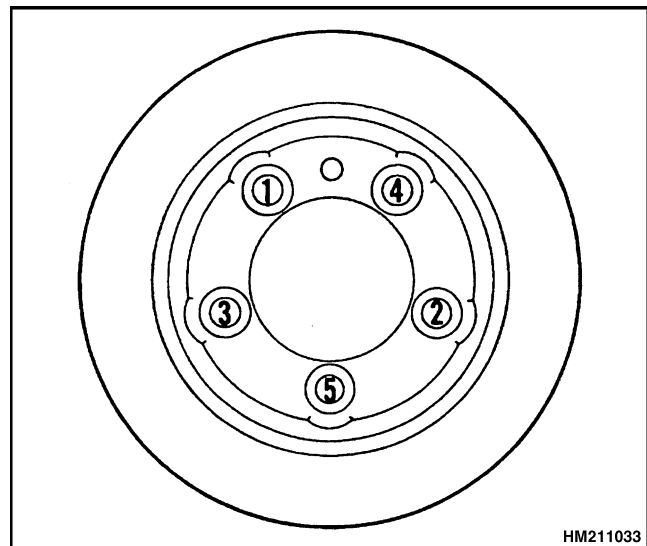

*Figure 6. Torquing Drive Wheel*

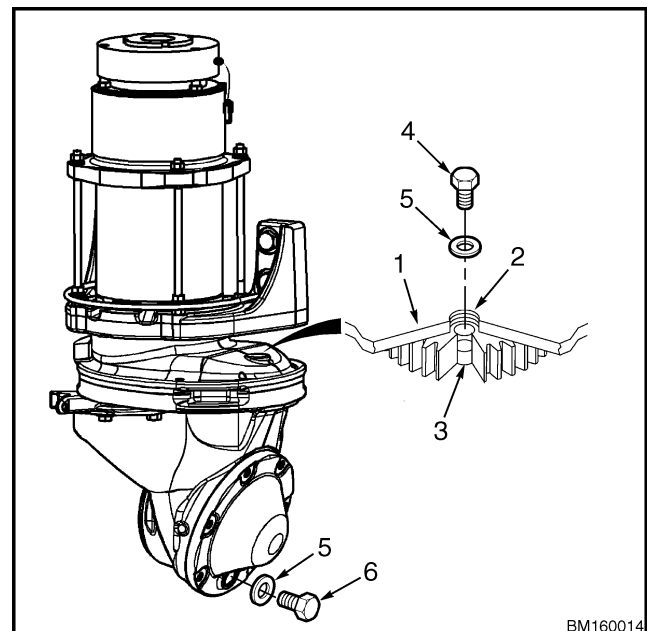

1. DRIVE UNIT HOUSING
2. OIL FILL HOLE
3. OIL LEVEL
4. FILL PLUG
5. WASHER
6. DRAIN PLUG

*Figure 7. Check Oil Level*

## MOTOR BRUSHES

### WARNING

Turn the key switch to the **OFF** position and disconnect the battery before making any checks on the motors. Personal injury or equipment and tool damage can occur if the battery is not disconnected.

### CAUTION

Low battery voltage causes the motor current to increase to do the same work. This higher current can damage the motor and the contactor contacts. **DO NOT** operate the lift truck if the battery has a specific gravity of 1.130 or less.

Inspect the brushes, brush springs, brush holders, and commutator every 350 hours on all electric motors. Use a vacuum cleaner or dry, low pressure compressed air under low pressure to remove any brush dust.

1. Move the truck to a safe location, turn the key switch to the **OFF** position, and disconnect the battery.
2. Remove the MDU compartment cover. See **Introduction** - Drive Unit Compartment Covers.
3. Tag and identify the electrical wires for proper reassembly. Disconnect the wires from the terminals.
4. Remove the brush band.
5. Move the brush spring and remove the brush from the holder. Inspect the commutator, see the section **DC Motor Maintenance** Brush and Commutator Inspection. All motor brushes must be replaced before they damage the surface of the commutator.

### WARNING

If the lift truck has been operated using a battery that is almost discharged, inspect for welded contacts **BEFORE** connecting a

charged battery. A contactor with welded contacts can cause operations that are not expected and possible injury when a charged battery is connected. Check the battery connector for damage.

6. Inspect the brushes. Replace brushes before they are worn to the values shown in Figure 8. Inspect the brush holders for burns or damage. Make sure the brush holder is fastened tightly to the mounts. Make sure the brushes will move freely and smoothly in the brush holders and do not have wire breaks. Inspect the brush springs for damage from heat (color changes) and corrosion. Replace a damaged brush spring.

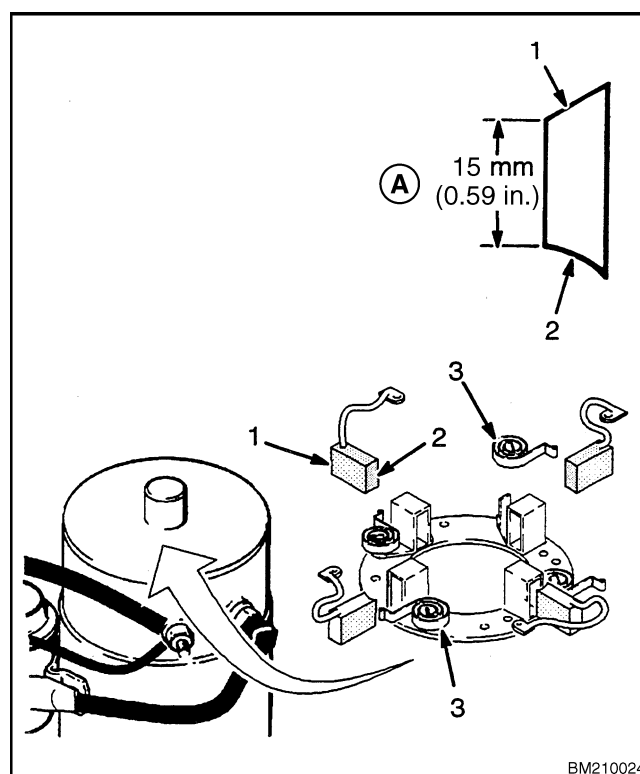

#### A. MINIMUM DIMENSION

- |                         |                 |
|-------------------------|-----------------|
| 1. TAPERED END (SPRING) | 2. WEAR END     |
|                         | 3. BRUSH SPRING |

*Figure 8. Traction Motor Brushes Inspection*

## Maintenance Procedures Every 2000 Hours or Yearly

**NOTE:** Perform these procedures in addition to the 8-hour and the 350-hour checks.

### LOAD WHEEL BEARINGS (T5Z AND T7Z)



#### WARNING

Move the lift truck to a level location where it can be serviced. Disconnect the battery and remove the key.

The lift truck must be put on blocks to perform maintenance on the load wheel bearings.

#### Remove

Follow the steps below to remove the load wheel bearings. See Figure 9.

1. Put the lift truck on blocks and disconnect the battery.
2. Remove hub cap (6) and attaching screws (7).
3. Remove cotter pin (10) from end of the axle shaft (14).
4. Remove nut (9) and washer (5).
5. Remove load wheel (15) and bearing assemblies by pulling the load wheel off the axle shaft.
6. Remove bearing cones (1, 4), and remaining washers (11, 12, 13, 8) from the axle shaft.
7. Remove the bearing cups (3, 2) **ONLY** if they are damaged and must be replaced.

#### Inspect

The bearing cups, cones, washers, and load wheels should be cleaned and inspected when removed. Any damaged parts should be replaced. To inspect the load wheel and bearings:

1. Wipe grease and dirt from bearing cups and cones, load wheel, washers, and axle shaft.
2. Wash the bearing cones in solvent to remove all dirt and grease.
3. Inspect the cups and washers for pits and grooves or other damage.

4. Inspect the cones for looseness, wear, and other damage.
5. Place bearing cone inside cup and slowly turn the cone while pressing down with the palm of the hand. The bearings should roll smoothly without interruption.

**NOTE:** If any damage is found on a bearing cup or cone, then **BOTH** the matching bearing cup and cone must be replaced.

#### Install

Install the load wheel assembly by reversing the order of removal until installing the nut (9) and then by following these instructions:

1. Install bearing cups to load wheel if removed.
2. Pack the wheel bearing cones with Amsoil® GHD synthetic multipurpose (lithium complex) with 2 to 4% molybdenum disulfide. The wheel hub cavity between the bearing cups should be packed with the same lubricant to a level even with the center of the bearing cups. Apply a light coat of grease to the spindle and the finished surface on which the oil seal rides.
3. Install washers (8, 13, 12, and 11) to axle shaft.
4. Install bearing cones to load wheel and install load wheel and bearing assemblies on to axle shaft.
5. Install washer (5) and nut (9) to axle shaft.
6. Tighten the wheel adjusting nut (9) while slowly rotating the wheel until wheel will not rotate. See Figure 9.
7. Back off adjusting nut (turn counterclockwise) 1/16 to 1/4 turn until slot in lock nut lines up with hole in axle shaft.

**NOTE:** Hub should turn freely with 0.0254 to 0.254 mm (0.0010 to 0.010 in.) end play.

8. Install cotter pin (10).
9. Place hub cap (6) over hub and align screw holes. Attach the hub cap with screws (7).

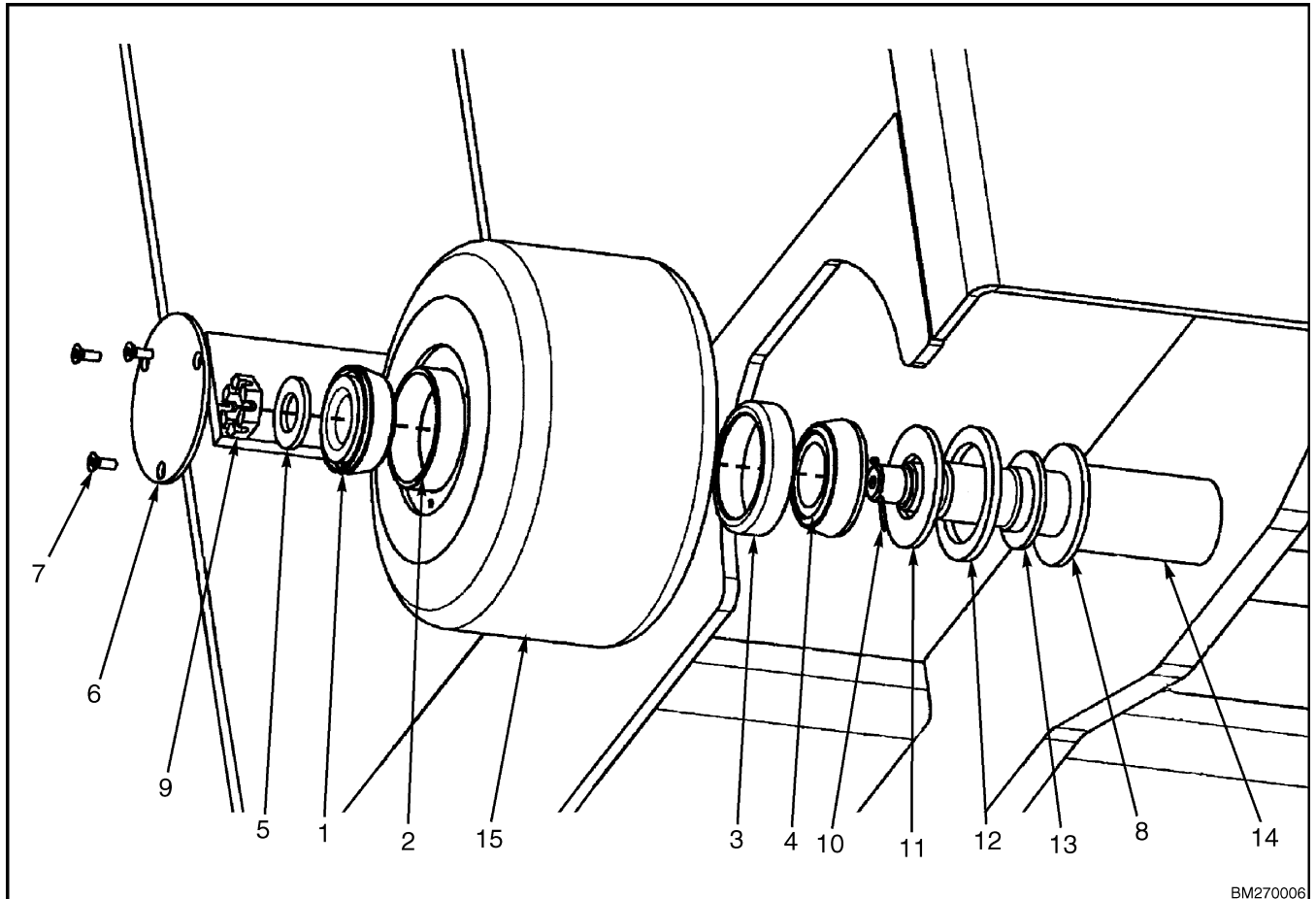

1. OUTER BEARING CONE
2. OUTER BEARING CUP
3. INNER BEARING CUP
4. INNER BEARING CONE
5. WASHER
6. HUB CAP
7. SCREW
8. WASHER

9. NUT
10. COTTER PIN
11. WASHER
12. FELT WASHER
13. WASHER
14. AXLE SHAFT
15. LOAD WHEEL

**Figure 9. Load Wheel Assembly (T5Z and T7Z)**

## CONTACTOR

**NOTE:** Perform these procedures in addition to the 8-hour checks.

### WARNING

Disconnect the battery connector before making any inspections or repairs. Personal injury or equipment and tool damage can occur if the battery is not disconnected. The charge on the capacitors can cause electrical shock and personal injury. Use an insulated screwdriver or jumper wire to make a short circuit across the capacitor terminals of the SCR controller to discharge each capacitor.

If the lift truck has been operated using a low battery, inspect for welded contacts **BEFORE** connecting a charged battery. A contactor with welded contacts can cause operations that are not expected and possible injury when a charged battery is connected. Check the battery connector for damage.

### CAUTION

Low battery voltage makes motors use high currents for a longer time to do the same work. These currents can damage motors and weld contactor contacts. Never try to repair contactor contacts that are welded. Always replace welded contacts. **DO NOT** operate the lift truck using a battery that has a specific gravity of 1.130 or less.

Disassemble the contactor to inspect the contacts.

### Inspecting the Contacts

1. Turn the key switch to the **OFF** position and disconnect the battery.
2. Remove the drive unit compartment covers.
3. Discharge the capacitor.
4. Disassemble the contactor to inspect the contacts.

Inspect the contacts. The contact surfaces of the contactor are a silver alloy over a copper base. In normal operation, the contact surfaces become a dark color and rough. Cleaning is not necessary. **DO NOT** use a file or emery cloth on the contacts. Replace the contacts of the contactor when the contact thickness is 30% of the thickness of a new contact. Replace the

contact if there is any metal transfer between the contacts. Always replace the contacts in sets. See the section **Electrical System** 2200 SRM 1052.

## HYDRAULIC SYSTEM (C60Z AND C80Z)

### Changing the Hydraulic Oil

### WARNING

Always wear the proper protective equipment including eye protection and petroleum-resistant gloves when handling hydraulic oil. Thoroughly wash oil from exposed areas of skin as soon as possible.

Completely lower forks to relieve hydraulic pressure before disassembling any part of the lift pump or disconnecting any hydraulic hoses.

The hydraulic oil is hot at normal operating temperatures. Be careful when draining the oil.

### CAUTION

Protect the hydraulic system from dirt and contaminants when servicing the hydraulic system.

Never operate the pump without the proper amount of oil in the hydraulic system. The operation of the hydraulic pump with low oil levels will damage the pump.

1. Move the lift truck to a safe and level area. Lower the forks completely to relieve pressure from the hydraulic system. Block load wheels to prevent lift truck from moving.
2. Turn the key switch to the **OFF** position and disconnect battery.
3. Remove the drive unit compartment covers.
4. Discharge the capacitor.
5. Tag and disconnect all power wires, control wires, and hoses to the lift pump and motor assembly.
6. If necessary, remove the battery.
7. Loosen and remove the three capscrews retaining the lift pump and motor assembly to the